

TABLE 1: TEST REQUIREMENTS	
GEOMETRY (TG):	SEE BOM ITEMS 600-603
LOSS - IL/RL (TL):	SEE BOM ITEMS 604-607
FIBERCHK (TF):	SEE BOM ITEMS 608-611

TABLE 2: POLARITY (MT12/1,1-1B,WHY-WHW-F)				
P1 END POSITION	FIBER COLOR	P2 END		
		BOOT-H/S	POS	LEG#
1	BLUE	WHITE-YEL	B	1
2	ORANGE	WHITE-WHT	A	2
3	GREEN	WHITE-YEL	B	3
4	BROWN	WHITE-WHT	A	4
5	SLATE	WHITE-YEL	B	5
6	WHITE	WHITE-WHT	A	6
7	RED	WHITE-YEL	B	7
8	BLACK	WHITE-WHT	A	8
9	YELLOW	WHITE-YEL	B	9
10	VIOLET	WHITE-WHT	A	10
11	ROSE	WHITE-YEL	B	11
12	AQUA	WHITE-WHT	A	12

TABLE 3: CUSTOMER PART# AND LENGTH			
CUSTOMER PART # (SEE PO)	LENGTH AND UNITS (xu)	TOLERANCE	PRODUCT LABEL DATA (product data, x = LENGTH)
SAMPLE (TBD)	xxxFT (xxx = 0-3)	(+0.25FT / -0)	MTPF/LC 12F xFT
	xxxFT (xxx = 4-25)	(+0.50FT / -0)	
	xxxFT (xxx = 26-50)	(+0.75FT / -0)	
	xxxFT (xxx > 50)	(+1.00FT / -0)	
SAMPLE (TBD)	xxxM (xxx = 0-7)	(+0.152M / -0)	MTPF/LC 12F xM
	xxxM (xxx = 8-15)	(+0.228M / -0)	
	xxxM (xxx > 15)	(+0.304M / -0)	

xxx = CUSTOMER ORDER LENGTH

REVISION HISTORY—ALL SHEETS ARE AT THE SAME REVISION				
ZONE	REV	DESCRIPTION	DATE	APPROVED
-	A	INITIAL RELEASE	07/03/19	JPEARCE
-	-	-	-	-

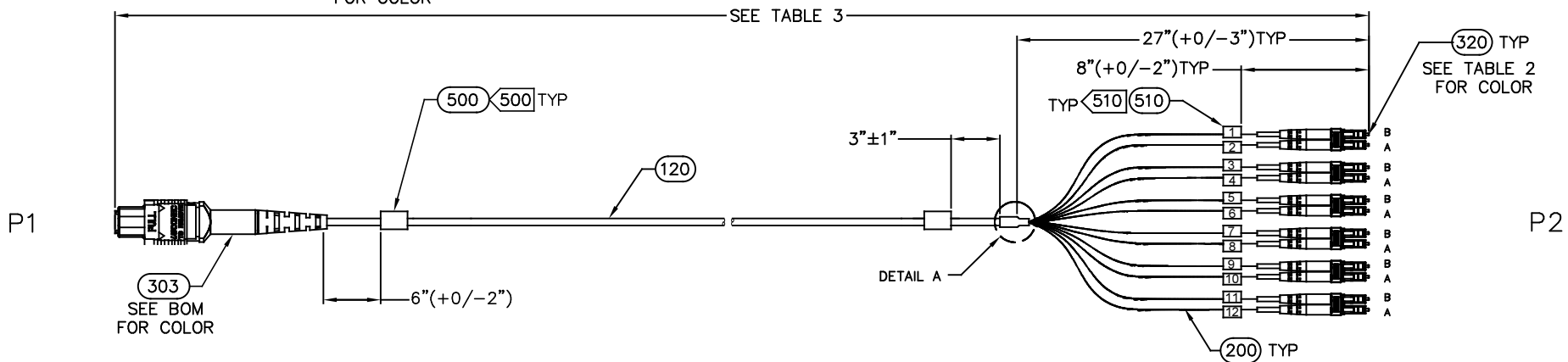
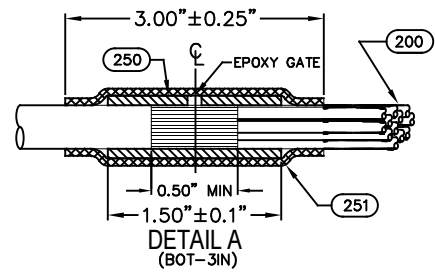
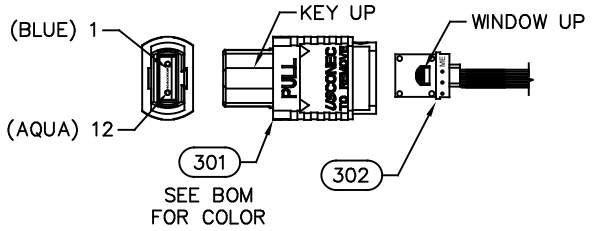

GENERAL NOTES UNLESS OTHERWISE SPECIFIED: (1450-HARN-1SUB-WPD)
 1. ASSEMBLY LENGTHS ARE FROM FERRULE TIP, CENTER OR EDGE OF TRANSITION, BLUNT END OR BACK OF BOOT
 2. ALL DIMENSIONS MEASURED WITH STRAIGHTENED LENGTH AND AFTER FINISHED
 3. ALL CONNECTORS SHALL BE SHIPPED WITH FERRULES PROTECTED BY REMOVABLE CAPS

500 LABEL TEXT:

customer part# product data so#-line#-assy#-mmdddy
--

510 LEG LABEL TEXT:

f

customer part# = SEE TABLE 3 FOR WO PART# OR DESCRIPTION
 product data = PRODUCT DATA IN TABLE 3 FOR WO PART# OR DESC
 so# = WO#, line# = LINE#, assy# = 001 THRU QTY (6-3-3)
 mm = MONTH, dd = DAY AND yy = YEAR OF MANUFACTURE

INSTALL LEG LABELS AS SHOWN
 f = FIBER LEG NUMBERS SHOWN ON DRAWING

- PULLING EYE: NOT REQUIRED
- REEL: >200 FEET BOM LENGTH, P1 END OUT

SEE BOM ON WORKORDER TRAVELER

	DESCRIPTION		DWG, 12F, MTPF/LC, 2.0, OPE NO_PULLEYE	
	DWG NO.	LCD12FMTPLC	CUSTOMER'S DWG NO.	N/A
	DRAWN BY:	JPEARCE	DATE:	07/03/19
	CHECKED BY:	TCARMODY	DATE:	07/03/19
APPROVED BY:	LARMSTRONG	DATE:	07/03/19	SCALE: NONE
				SHEET 1 OF 1
				REV A